

OCEAN TECHNOLOGY SYSTEMS



Spectrum Full-Face Mask

Owner's Manual



IMPORTANT INFORMATION



**PLEASE REFER TO OUR WEBSITE AT :
WWW.OCEANTECHNOLOGYSYSTEMS.COM
FOR MORE INFORMATION ABOUT THE SPECTRUM
FULL FACE MASK**

**REVIEW MANUAL AND EMERGENCY PROCEDURES
BEFORE DIVING THIS EQUIPMENT. FAILURE TO
COMPLY MAY RESULTS IN INJURY OR DEATH.**

TABLE OF CONTENTS

- Important Safety Notice -	4
Introduction	5
Warnings and Precautions	6
Description	7
What is a “Full-Face Mask?”	7
Environmental Protection	7
Physiological Considerations	7
Communications.....	8
Anatomy of the Spectrum Full-Face Mask.....	8
Head Harness Assembly.....	8
Drain Tab	9
Visor Drain Holes	9
Inner Frame.....	9
Setting up the Spectrum Full Face Mask	10
Acceptable Zip-Ties for Installation.....	10
Installing Second Stage Regulator.....	10
Inner Frame Installation	11
Regulator Removal.....	11
Inner Frame Removal	12
Acceptable Second Stage Regulators	12
Regulator Exhaust Tees.....	13
Donning and Doffing Procedures	13
Overall Safety Inspection	13
Hoods and Seals.....	13
Donning and Adjustment.....	14
Doffing.....	15
Diving The Spectrum Full-Face Mask	15
Pre-Dive	15
Post-Dive Procedures	15
Warning Note.....	16
Training and Emergency Procedures	16
Emergency Procedures	17
Installation of Communications	18
Buddy Phone® Installation Instructions	19
EM-OTS-2 Installation Instructions	20
Specifications	21
Limited Warranty	22

- NOTICE -

This manual and the information contained herein are provided for use as a maintenance and operation guide. No license or rights to manufacture, produce, and/or sell either the manual or articles described herein are given. Undersea Systems International, Inc., dba Ocean Technology Systems hereinafter referred to as OTS, reserves the right to change specifications without notice. We recommend that all users read and fully understand this manual before using a Spectrum Full-Face Mask (FFM).

All statements, technical information, and recommendations herein are based on tests we believe to be reliable, but the accuracy or completeness thereof is not guaranteed; and the following is made in lieu of all warranties, expressed or implied, including the implied warranties of merchantability and fitness for purpose: Seller's and Manufacturer's only obligation shall be to replace such quantity of the product proved to be defective. Before using, the user shall determine the suitability of the product for intended use, and the user assumes all risk and liability whatsoever in connection therewith. Neither Seller nor Manufacturer shall be liable either in tort or in contract for any loss or damage—direct, incidental, or consequential—arising from the use of or the inability to use the product. No statement or recommendation not contained herein shall have any force or effect unless it is in an agreement signed by officers of the Seller and Manufacturer.

- IMPORTANT SAFETY NOTICE -
(Please read before using product)

It is absolutely essential that all users are certified divers in good standing, properly trained, equipped, and fully understand this user's manual before attempting to use the Spectrum FFM. While the Spectrum FFM does provide the diver with outstanding underwater environmental protection, *it does not change or eliminate the potential hazards of diving!*

Refer to the User Manuals page of our Web site at, www.oceantechnologysystems.com for a list of any changes made to this manual since its publication.

© Copyright 2018 by Undersea Systems International, Inc., dba **Ocean Technology Systems**. All rights reserved.
Specifications are subject to change without prior notice.

INTRODUCTION

Congratulations on the purchase of your new OTS Spectrum Full-Face Mask! This full-face mask (FFM) is one of the few that has been designed from the ground up as a **scuba diving** mask. The Spectrum FFM was designed with comfort, fit, and function in mind. Having been in the underwater communications business for over three decades, Ocean Technology Systems (OTS) created the Spectrum FFM based around what we've learned from listening to the needs of our customers. Our goal was to design a product that was comfortable, fit the vast majority of the diving population, was simple to use, easy to maintain and would fit most 2nd stage regulators. More importantly, it had to be rugged and perform as well or better than anything on the market.

OTS is proud to provide you with this advanced diving apparatus and hope you enjoy it as much as we do.

All who intend to use this Spectrum FFM must read this manual carefully prior to preparing and using this equipment. Training must be obtained before using this or any other advanced diving equipment. Become familiar with emergency procedures and ensure you are equipped with proper bailout equipment appropriate for the type of diving you are performing. If you have any questions or don't fully understand this manual, please contact OTS directly or an authorized OTS Dealer (OTS contact information is listed under the "Limited Warranty" on page 22).





Danger Note

- Undersea Systems International Inc. dba Ocean Technology Systems cannot guarantee diver's protection from contaminated diving environments, including but not limited to : biological, chemical, radioactive contaminants.

WARNINGS AND PRECAUTIONS

While reading and reviewing this manual, please note the following indicators for Warnings and Dangers:

 Warning Note	The “Warning” symbol indicates something that might cause damage to the equipment, or, if not properly performed, may lead to a hazardous situation that could cause injury or death.
 Danger Note	The “Danger” symbol indicates a most important point that if not avoided will result in a situation that causes injury or death.

 Warning Note
<ul style="list-style-type: none">• Diving a Spectrum Full-Face Mask or any scuba diving equipment without proper training and experience can result in serious harm or death.• This is an advanced piece of diving equipment that requires special training and practice prior to diving it in an open water environment. Proper maintenance and care of this equipment is essential for safe operation.• Always inspect the Spectrum Full-Face Mask for damage prior to diving if you suspect it has been subjected to any abuse, tampering, or impact.• It is YOUR responsibility to insure that your equipment is in good condition and operating properly. Remember, this is LIFE SUPPORT EQUIPMENT!• Diving is an inherently dangerous sport. Participating in this activity puts you at risk of serious injury or even death.• Prior to diving the Spectrum FFM, ensure it is clear of all packing materials or any other foreign debris.

DESCRIPTION

What is a “Full-Face Mask?”

The OTS Spectrum FFM differs from standard scuba equipment in that the second-stage regulator is incorporated into the mask and the mask covers your “full” face, hence the term.

There are four primary reasons to dive a Spectrum FFM:

1. Environmental protection
2. Physiological considerations
3. Communications
4. For the fun of it

Environmental Protection

Anytime a diver is in water that would be considered less than healthy (e.g., biological/chemical contamination, extreme cold, etc.), protection is of the utmost importance. The Spectrum FFM affords a significant protection advantage over that of a standard bite regulator and mask. While not a substitute for full protection as required in hazmat diving, the Spectrum FFM can add protection in contaminated water that standard equipment cannot. This configuration is commonly seen in light commercial and public safety diving.

Physiological Considerations

The Spectrum FFM protects the diver in other ways as well. If, for any reason, a diver were to become unconscious underwater, the Spectrum FFM is able to maintain a breathable airspace in front of the diver’s nose and mouth assisting in survival (assuming the scuba tank has air). This aspect of the Spectrum FFM is extremely useful for divers with TMJ, dentures, disabilities, and for those divers using high concentrations of oxygen (convulsion risk).



Warning Note

- Diving a Spectrum Full-Face Mask or any scuba diving equipment without proper training and experience can result in serious harm or death.
- This is an advanced piece of diving equipment that requires special training and practice prior to diving it in an open water environment. Proper maintenance and care of this equipment is essential for safe operation.

Communications

In order to use underwater communications, an airspace is required to allow for articulation and placement of a microphone. The Spectrum FFM has an oral/nasal cavity that provides optimal communications, while some FFMs have the nose separated from the mouth. This separation alters the voice slightly, as in pinching your nose when talking and does not achieve optimal underwater communications.

Anatomy of the Spectrum Full-Face Mask

Front Aspect

KEY:

1. Upper Lens Clamp
2. Lower Lens Clamp
3. Push-to-Talk (PTT) Communications Port**
4. Drain Tab
5. Regulator Port
6. Inner Frame Port
7. Visor Drain Holes (located inside mask)
8. Tempered Glass Visor
9. Accessory Attachment Points
10. Accessory Attachment Point
11. Buckle (5 total)



Figure 1: Front of Mask

**Shown with communications PTT switch (not included)



Figure 2: Five-Point Head Harness

Head Harness Assembly

The Spectrum FFM uses a five-point strapping system (Figure 2). Buckles are mounted by a button securely on tabs that are a part of the skirt. If needed, they are replaced easily by stretching the tab and either removing or replacing the button end of the nylon buckle.

Drain Tab

The Purge Drain Tab is located under the chin pocket of the mask and is designed to help fully eliminate any residual water remaining after a flood and clear of the mask. After clearing the majority of the water out via the regulator purge button simply pull down on the tab and blow out any remaining water.

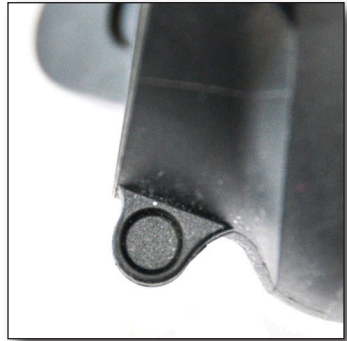

Figure 3: Drain Tab

Visor Drain Holes

The Spectrum features two Visor Drain Holes located in the inside of the mask on the top of the oral nasal pocket where the “teardrop” portion of the visor meet. The holes are designed that if water pools in the visor, it will drain into the oral nasal pocket where it can then be evacuated by blowing out the nose or mouth, or by using the purge button of the 2nd stage regulator.



Figure 4: Visor Drain Hole

Inner Frame

The inner frame located in the oral nasal pocket is key in properly mounting a second stage regulator into the Spectrum FFM. The purpose is to add rigidity to the mask while adding the least amount of weight as possible. When the inner frame is properly implemented, the oral nasal pocket is significantly strengthened. This reduces the amount of “push / pull” effect of the second stage regulator when inhaling & exhaling, as well as limiting the range of motion of the regulator.



Figure 5: Inner Frame

SETTING UP THE SPECTRUM FULL FACE MASK

Acceptable Zip-Ties for Installation

Prior to installing second stage regulator into the Spectrum FFM, ensure the inner frame is not installed and the regulator port is not damaged. Locate the zip tie included with the Spectrum FFM. **(Only use a military standard MS3367-7-0 zip tie).**

Installing 2nd Stage Regulator

Remove bite mouth piece (if installed) from second stage regulator. Insert second stage regulator mouthpiece tube into the regulator port through the front of the Spectrum FFM. Ensure the end of the regulator port corresponds with the end of second stage regulator.



Figure 6: Installing Regulator



Danger Note

- It is vital that installing the zip-tie into the Spectrum FFM is done correctly with the specified zip-tie. Improperly installing the zip-tie and regulator can result in the regulator becoming dislodged from the mask resulting in possible injury or death!

Install zip tie tightly around second stage regulator so that it wraps around and fastens the mouthpiece tube securely to the Spectrum FFM. Ensure the ratchet of the zip tie is oriented along the horizontal axis of the regulator port (Figure 7).

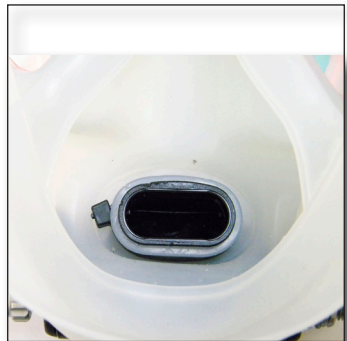

Figure 7: Install Regulator

NOTE : Figure 7 & 8 shown in a clear skirt for contrast. Clear skirts are not available for purchase

Inner Frame Installation

It is vital that the inner frame is installed prior to diving. Route the end with the threaded OTS cap through the left side of the oral nasal pocket. The right side of the inner frame should fit around the outside Push-To-Talk button assembly in the oral nasal pocket or the comm port plug if no communications are installed. Verify that the Inner Frame is not between the head of the zip tie and the FFM skirt (Figure 8). Once installed, tighten down (clockwise) the inner frame using the additional comm port cap (Figure 9). The cap should be snug.

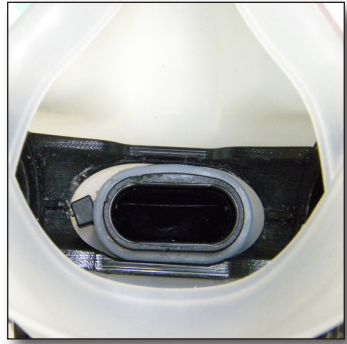

Figure 8: Install Inner Frame

Verify that the inner frame is not between the zip tie's ratchet and the FFM skirt. See Figure 8 for a correctly installed regulator and inner frame. Give a slight tug to ensure the regulator is secured correctly.



Figure 9: Tighten Inner Clamp Port

Regulator Removal

Using a pair of wire cutters or pliers, crush the head of the zip tie around the second stage regulator and carefully pull second stage regulator mouthpiece tube out of the regulator port of the Spectrum FFM. **DO NOT USE ANY SHARP OBJECTS TO REMOVE ZIP TIE OR REGULATOR. DOING SO MAY DAMAGE OR TEAR THE SKIRT OF THE MASK.**



Figure 10: Regulator Removal

Inner Frame Removal

To remove the inner frame, remove the second stage regulator and then unscrew (counterclockwise) the right cap with the included OTS wrench. Once the cap is off, stretch the skirt of the mask and lift the Inner Frame in and out of the oral nasal pocket.



Figure 11: Inner Frame Removal

Acceptable 2nd Stage Regulators

The regulator port of the Spectrum allows regulators from 3/16" x 5/8" and sizes up to 1-7/16" x 13/16".

NOTE : The regulator port can be safely stretched up to 50% to allow bigger sized mouthpiece tubes.

Ensure the mouthpiece tube of regulator being installed has one single lip that has a minimum length of .50" (See Figure 12) and is not double lipped. **DO NOT USE REGULATORS THAT HAVE A DOUBLE LIPPED MOUTHPIECE.**

A properly secured mouthpiece and regulator should be able to withstand a weighted pull test of 25 pounds for 25 seconds.

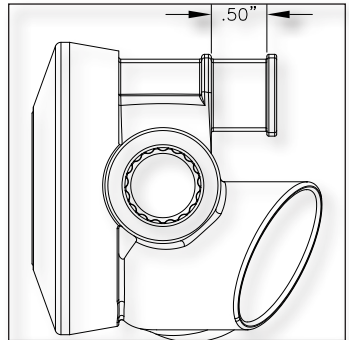

Figure 12: Minimum Mouthpiece Tube Length

NOTE : Not all second stage regulators available can be properly mounted.

Regulator Exhaust Tees

The size of the regulator mouthpiece tube and size of the exhaust tees can affect performance of the mask. An incorrectly installed regulator can lead to flooding of the mask, which may result in serious injury or death. If the regulator has exhaust tees, ensure they do not interfere with the mask and there is a clear path for gas to exhaust.

DONNING AND DOFFING PROCEDURES



Warning Note

ALWAYS inspect your diving equipment to ensure it is not damaged or defective and that it is fully functional. DO NOT dive the Spectrum FFM or any other equipment if you have not verified that it is in good condition and working properly! If this equipment has been damaged, tampered with, or found to be defective, return it to OTS or replace components immediately.

Overall Safety Inspection

Prior to donning the Spectrum FFM, examine the complete assembly along with the rest of the gear to ensure that it is in dive-ready condition. The diver is ultimately responsible for his/her equipment. Check all buckles, strap assembly, visor clamp assembly, visor, skirt, inner frame and regulator. Then extend all straps and prepare to don the mask. Establish equalization is achievable.

Hoods and Seals

To achieve the best seal, the mask skirt should be fitted **directly** onto the skin of the diver's face (Figure 13). Do not attempt to seal over or against a neoprene hood as this will result in leaking, excessive air consumption, and hood inflation. A neoprene hood can be trimmed to allow for the mask to seal properly against the face.

For dry suits that have latex seals, the mask may be worn directly over the hood. This type of hood allows for the mask to seal properly over the hood and the hood seals to the face.

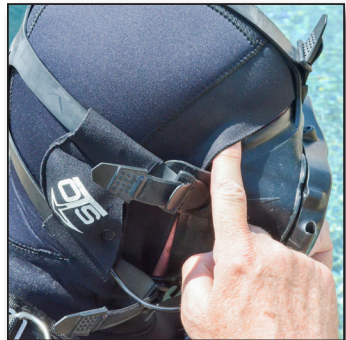

Figure 13: Fit Mask Skirt onto Skin, Not Hood

Donning and Adjustment

Proper donning of the Spectrum FFM is crucial when using diving equipment. An improperly adjusted mask will result in jaw fatigue, increased air consumption, leaking, and an overall poor fit.

First and foremost the Spectrum FFM must be fitted to the chin; the rest of the mask will seal to the face where it lays.

With the mask straps fully extended, move the communications (either the Buddy Phone or EM assembly) as far as possible to the rear of the straps to prevent them from binding against the buckles. Open the lower straps and bring the mask and harness over the head (Figure 14). Ensure the harness is straight and the center is low on the back of the head.



Figure 14: Open Lower Straps and Bring Over Head

Hold the Spectrum FFM to the face with one hand and tighten the lower (jaw) straps one at a time, switching hands to accommodate tightening the other. Pull the straps toward the back of the head, **not** out to the side.

Tighten the straps evenly to prevent pulling the back of the head harness off center. Do not overtighten.

Next, tighten the temple straps evenly. If necessary, tighten the top strap just enough to pull the top of the skirt tighten to the forehead. **DO NOT OVERTIGHTEN THE TOP STRAP!** This can result in jaw fatigue after just a short period of time. Wiggle the Spectrum FFM on the face to ensure the mask is in proper position and centered with no stress points. Evenly tighten the straps (Figure 15) to the desired tension, again not overtightening the straps. The mask should be comfortable on the face.



Figure 15: Tighten Straps Evenly

Overtightening the top strap will cause the center of the head harness to sit high on the back of the head. This results in the mask being pulled **up** on the face and not **back**, as desired. Consequences of this error include possible leaking, jaw fatigue, and an uncomfortable dive. If there is the need to tighten the top strap, pull down on the back of the head harness to ensure its proper positioning low on the back of the head. Tighten the top strap as necessary.

Finally ensure equalization is achievable.

Doffing

To remove the mask (Figure 16), grasp the bottom of the mask with both hands and use thumbs to grasp bottom buckle tabs and loosen. Then, pull the mask out and off of the head.



Figure 16: To Remove Mask, Use Thumbs to Grasp Bottom Buckle Tabs and Loosen

DIVING THE SPECTRUM FULL-FACE MASK

Pre-Dive

Prior to entering the water, check the submersible pressure gauge (SPG). This is done by taking two deep breaths through the mask while observing your SPG. There should be a **slight** drop in pressure. If there is a significant drop in pressure, check that the air supply is working properly. If the gauge shows a drop, and the air supply is turned on correctly, have the equipment examined immediately for proper function.

Post-Dive Procedures

After a diver has completed diving, remove the Spectrum FFM. Thoroughly rinse the Spectrum FFM in clear, fresh water and pat it dry with a lint-free absorbent cloth. If necessary, a mild detergent may be used for cleaning the Spectrum FFM. **Never** use any harsh detergents, abrasives, or solvents on your Spectrum FFM. Use caution when drying the visor after diving in a sandy environment to prevent any scratching of the lens. **Do not use** paper towels to dry or clean visor—scratching of the lens may occur.

Hang the Spectrum FFM upside down to allow for any trapped water to drain to the top of the skirt. Wipe out the excess water and allow the Spectrum FFM to air dry prior to storing. If stowing a damp mask, remove it from the bag as soon as possible and allow it to dry completely to prevent any mold and mildew from forming.

Rinse the Spectrum FFM and regulator with fresh water. Shake any remaining water from the Spectrum FFM.



Warning Note

If the Spectrum FFM has been exposed to contaminated water it should be cleaned.

Training & Emergency Procedures

As with any high-tech equipment, the Spectrum FFM does require additional training and practice. Air sharing in an out-of-air situation is more difficult, often requiring bailing out of the mask (depending on the gear configuration).

Regardless of prior FFM diving experience, take some time to dive the Spectrum FFM in a pool or similar environment. Follow the guidelines in this manual and seek additional instruction if necessary. Learning how to dive the Spectrum FFM to a point that feels **completely** comfortable with all aspects is critical. In addition to procedures on using the equipment, there are emergency procedures for out-of-air (OOA) situations and possible equipment failure situations requiring bailout and switching to an alternate air source. Do not dive this assembly or any equipment until properly mastering these emergency procedures!

As part of the basic familiarization with the Spectrum FFM, bailout procedures are a **required** skill. In the event of an OOA situation, the diver must have an available source of back-up air. A pony bottle or dive buddy needs to be close by. A practice session should start in the shallow end of a swimming pool or similar environment, working either at the bottom or a fixed point so not lose control of depth or position in the water column.

Additional training and procedures are recommended in diving in extreme cold / ice environments.

FOR BAILOUT PROCEDURES:

- ALWAYS have an available source of back-up air (pony bottle, dive buddy, etc.) and know its location.
- Do NOT hold your breath!
- Start practice sessions in shallow end of swimming pool or similar environment.
- During practice, work at the bottom or a fixed point in the pool.
- It is recommended that you carry a spare mask.

Emergency Procedures

First, know the location of the alternate air supply, then remove the Spectrum FFM. This is best done by grasping the bottom of the mask and placing the thumbs on the lower buckle tabs. Pull out on these tabs, loosening and rotating the mask forward and back over the head. Exhale slowly, do not hold breath. Obtain the alternate air source, clear the regulator, and breathe normally. Don a spare mask, or terminate the dive without one.

This skill takes practice and preparation! Keep working on the bailout technique until mastering this skill.

Another important skill is donning the mask while underwater. Begin by setting up the mask in the same way as donning it on the surface (extending the straps, pulling any communications to the rear, etc.). Prepare to be without air for the short time it takes to perform this exercise. Remove the spare mask, if applicable, as well as the alternate air source. Again, **do not hold breath**. Slightly exhale continuously. Drop the mask over the head and press the mask to the face.

To clear the mask of water, if you have sufficient air in your lungs, start to exhale as this will displace the water and clear the mask. At the same time, look up at about a 45° angle, pull out slightly on the bottom of the mask, then push the purge on the regulator halfway. This will clear the majority of the water from the mask.

If there is not sufficient air in the diver's lungs, push the purge button of the diver's regulator until the mask is cleared of water.

Take a cautious breath to ensure the mask has cleared and to prevent inspiring any residual water. After the first inhalation, pull down on the drain tab, look down and exhale **forcefully** to clear any remaining water. Repeat this forceful exhalation a few more times. Again, ensure this skill is mastered.

Training Tips

Upon surface entry, secure the mask to the face with one hand. Breathe normally and **never** hold your breath. Upon descending, equalize, early and often, prior to experiencing any pain or significant pressure. Stop descending if equalization cannot be achieved or if pain occurs, descending **only** if proper equalization can be achieved.

If the mask requires adjustment while diving, tighten or loosen the straps as required. Be careful not to overtighten. Inflate Buoyancy Compensating Device (BCD) and swim on back if a surface swim is required. It is recommended that removal of the mask occurs only after exiting the water. This is important if the quality of water is contaminated.

Note: The diver should plan the dive to be back to the boat or beach while air is still available in the tank.

INSTALLATION OF COMMUNICATIONS

The Spectrum FFM is designed to accept Ocean Technology Systems (OTS) communications. There are two primary communication systems designed specifically for the mask: The Buddy Phone® (see **“Buddy Phone® Installation Instructions” on page 19**) and the OTS earphone and microphone assembly (see **“EM-OTS-2 Installation Instructions” on page 20**).



Figure 17: The Blanking Plug

The Buddy Phone is a stand alone communications system designed with the transceiver mounted on the head harness located on the right side of the diver's head. The Buddy Phone has a built-in earphone.

The OTS earphone and microphone (EM) assembly is for all other through-water and hardwire communications systems. Regardless of the system, the EM assembly mounts to the mask in the same manner.

If the Spectrum FFM was purchased without communications equipment, there will be a blanking plug installed in the communications port. This consists of a plug on the inside (of the mask) secured with a threaded, locking ring on the outside (Figure 17). To remove, use the OTS wrench (P/N 137053-000) to unscrew the locking ring counterclockwise and remove the plug from the inside.

BUDDY PHONE® INSTALLATION INSTRUCTIONS

Refer to Figure 13 and proceed as follows:

1. Locate the communications port on the right side of the mask. Unscrew (counterclockwise) the fastening nut from the plug using OTS wrench. Remove the plug and store for possible future use (Figure 12 on page 18).
2. Loosen (counterclockwise) the captive fastening nut on the microphone and push-to-talk (PTT) module of the Buddy Phone. Allow enough space between the fastening nut and the base of the module to accept the lip of the mask.
3. Insert the microphone and PTT module into the mask's right communications port. The nickel microphone wires may need to be bent slightly to install.
4. Continue inserting the microphone and PTT module into the communications port. The lip of the mask should go over the base of the module and rest between the base and the fastening nut.
5. The fastening nut is then screwed down clockwise until tight against the mask. The Buddy Phone cable should be pointing towards the Buddy Phone above the right ear.
6. Once the microphone is inside the port, carefully position it within 1/4" of the right corner of the diver's lips. The port accepts either the ME150 Microphone, ME-16R Hot-Mic, or Super Mic.
7. Fully insert the upper right head strap of the mask into the strap retainer slot on the OTS-BUD-D2 so that the Buddy Phone will be positioned above the right ear. Stretching the strap will make it easier to slip into the slot.
8. Before donning the mask, position the Buddy Phone as far back as possible to allow for tightening of the mask straps. Once fitted, adjust the Buddy Phone over the right ear as needed.

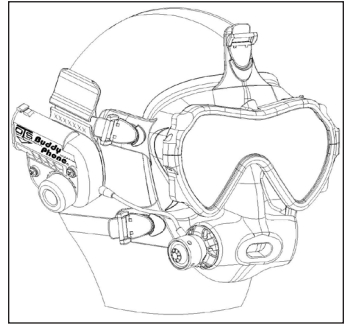

Figure 18: Spectrum FFM with Buddy Phone®

Note: In most cases of weak or bad communication, OTS has found that the microphone has been installed under the seal and toward the chin. The microphone needs to be clear of the seal and in the correct position for good, clear communications.

EM-OTS-2 INSTALLATION INSTRUCTIONS

Refer to Figure 11 and proceed as follows:

1. Locate the communications port on the right side of the mask. Using the OTS Wrench, unscrew (counterclockwise) the fastening nut from the plug and remove. Remove the plug from inside and store for possible future use (Figure 17 on page 18).
2. Loosen (counterclockwise) the captive fastening nut on the microphone and push-to-talk (PTT) module of the earphone and microphone assembly. Allow enough the base of the module to accept the lip of the mask.
3. Insert the microphone and PTT module into the mask's right communications port. The nickel microphone wires may need to be bent slightly to install.
4. Continue inserting the microphone and PTT module into the communications port. The lip of the mask should go over the base of the module and rest between the base and the fastening nut.
5. The fastening nut is then turned clockwise until tight against the mask.
6. Once the microphone is inside the port, carefully position it within 1/4" of the right corner of the diver's lips. The port accepts either the ME150 Microphone, ME-16R Hot-Mic, or Super Mic.
7. The left earphone cable travels snug up the right side of the visor and over the top by tucking the wire into the groove between the mask and visor.
8. Insert the temple and jaw mask straps through the top and bottom slots of each earphone holder, respectively. The snaps face toward the front of the mask with the OTS logo on each earphone holder upright. Reassemble the mask straps.
9. Insert the earphone into the earphone holder (on each side) past the snaps with the cable positioned below the snap. Secure the snap.
10. The earphone cable should exit the holder below the snap and run parallel with the mask straps.

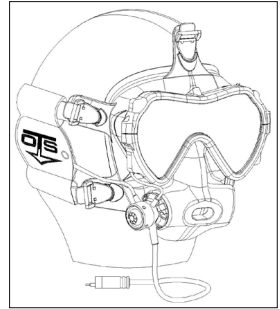

Figure 19: Spectrum FFM with EM-OTS-2

Note: In most cases of weak or bad communication, OTS has found that the microphone has been installed under the seal and toward the chin. The microphone needs to be clear of the seal and in the correct position for good, clear communications.

SPECIFICATIONS

- OTS Spectrum Full-Face Mask is tested to a maximum diving depth of 50m according to EN 250:2014**
- OTS Spectrum Full-Face Mask is designed for water temperatures below 10°C and is suitable for cold-water diving applications. Ultimately, cold water performance is dictated by 2nd stage regulator being used.
- OTS Spectrum Full-Face Mask is tested for diving applications with breathing air according to EN12021.
- OTS Spectrum Full-Face Mask has been tested according to the European standard EN 250:2014**

***EN250:2014 refers to the 2014 European Standard for Respiratory equipment - Open Circuit Self-Contained Air Diving Apparatus.*

*The mask carrying the mark CE 0120 had EC Type Examination conducted by:
SGS United Kingdom Limited
Unit 202B, Worle Parkway
Weston-super-Mare, BS22 6WA , UNITED KINGDOM"*

Material	Description
SILICONE	SPECTRUM SKIRT
BLACK PPS	UPPER / LOWER VISOR CLAMPS
TEMPURED GLASS / IRIIDIUM	VISOR
EPDM / NATURAL RUBBER BLEND	STRAP, MASK
GLASS FILLED ZYTEL®	BUCKLES / BUCKLE LOCKS
GLASS FILLED ZYTEL®	INNER FRAME

NOTES:

NOTES:

Undersea Systems International, Inc.

dba

Ocean Technology Systems

LIMITED WARRANTY

The Spectrum Full-Face Mask (FFM) is fully warranted against defects in materials and workmanship, including labor, for a period of one year from the time of purchase. Our obligation under this warranty is limited to the replacing of any part or parts which prove to our satisfaction to have been defective and which have not been misused or carelessly handled.

You must contact an official Ocean Technology Systems (OTS) Service Center or OTS directly to obtain service. If you elect to send the item/s to OTS, you must call and obtain an RMA number from our Repair department. The complete unit and/or damaged part shall be returned to our factory, transportation charges prepaid. We reserve the right to decline responsibility where repairs have been made or attempted by any party other than an OTS service factory trained center or properly trained personnel.

In no event shall OTS be liable for consequential damages related to our product/s.

Warranty registration is required. Any parts requiring replacement due to excessive wear or damage are not covered in this offer. Customer will be notified of any additional charges for worn or damaged components. The customer is responsible for shipping charges to the factory. OTS will pay shipping limited to the continental United States via UPS Ground service or equivalent. Any other shipping requirements are the responsibility of the customer.

Undersea Systems International, Inc.

dba

Ocean Technology Systems

3133 West Harvard St., Santa Ana, CA 92704 USA

Telephone: 714.754.7848 Fax: 714.966.1639

E-Mail: ots@otscomm.com

Web: www.otscomm.com

© Copyright 2018 by Undersea Systems International, Inc., *dba*
Ocean Technology Systems. All rights reserved. Specifications subject to change
without prior notice. Part Number : 506272-000 B